

# Smart Lighter Lifter User Manual

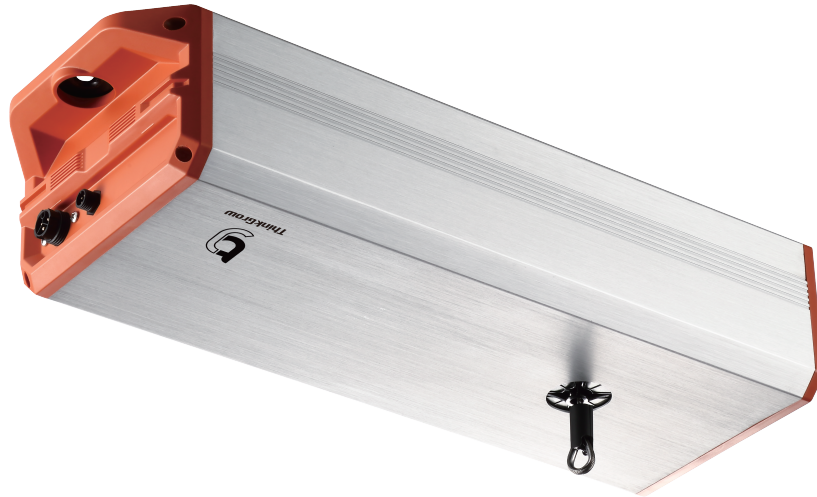

LLT-1 | ThinkGrow Smart Lighter Lifter & LRC-1 | Smart Lifter Remote

## • SAFETY PRECAUTIONS

Read the installation and operation instructions carefully before installing and operating this device. Proper adherence to these instructions is essential.

The maximum amperage for the Light Lifter is 1.5 amps.

The maximum weight for the Light Lifter is  $\leq 132\text{lbs} / 60\text{kg}$ .

## • WARNING

Users are responsible for the connection and safe installation and usage of the devices.

It is highly recommended that a certified person or licensed electrician install your light lift system.

---

Ensure the existing electrical system can support the voltage and current requirements.

The light lifter is heavy. Serious injury and/or equipment damage may result if dropped. Be careful when installing. Secure the light lift with appropriate mounting hardware. Follow the installation instructions carefully.

Ensure that the building structure, mounting solutions and components used can withstand the weight of the lifter and the light fixtures.

## • **CAUTION**

Read all instructions carefully before installation.

This product is not intended for use by children and any persons with reduced physical, sensory or mental capabilities or lack of experience and product knowledge.

The device is designed to be installed INDOORS IN A SPACE THAT IS PROTECTED FROM RAIN AND FLOODING.

General maintenance is not required. DO NOT clean the interior, steel cable of the light lifter with any chemicals that might cause damage. To clean the steel cable, use a damp cloth only, let the steel cable fully dry before retracting the cable.

# **ThinkGrow Smart Light Lifter (LLT-1)**

## • **OVERVIEW**

The LLT-1 light lifter is part of the ThinkGrow modular light lifter system. Its cutting-edge synchronized multi-lifter operation provides users with a customizable, expandable and easy-to-install system. The lifter is ETL listed. Each lifter can lift up to wp to 132lbs, and up to 8.8ft.

The light lifter design enables easy, two-man installation. Unlike the traditional pulley system where precise calculation and teams of engineers are needed, the LLT-1 reduces assembly time and manpower without compromising quality or safety. The easily expandable modular lifter system provides maximum flexibility and user customization. The System can also connect to the Hydro-X Pro Control System for additional advanced features.

The ThinkGrow Smart Light Lifter System is engineered to be a modular design, allowing multiple lifters to be synchronized together by daisy-chaining them. Users can connect, control & program synchronized operations.

## • SPECIFICATION

Input Voltage:	100-240V~, 50/60Hz
Input Power:	≤100W
Lifting Range:	≤ 8.8 ft / 2.7m / 106inchs
Maximum Lifting Weight:	≤ 132lbs / 60kg
Working Environments:	Temperature 32~104°F (0~40°C) Humidity ≤90%RH
Package Dimensions (L*W*H):	22.52" x 10.31" x 7.28" 572mm x 262mm x 185mm
Weight:	22.7lbs / 10.3kg

## • PACKAGE CONTENTS

1 x ThinkGrow Smart Light Lifter (LLT-1)  
1 x Power Cable

1 x 12ft RJ12 to 4-Pin IP65 Connector Cable (ECS-9)  
1 x Lifter Rigging Cable Kit (RC-1)

## • INSTALLATION

The LLT-1 module can be mounted directly to a ceilingjoist, unistrut or other secured structures using appropriate fasteners to secure the LLT-1.

Ensure the mounting solution is rated and installed by a certified professional. The mounting structure must be able to support the weight of the LLT-1 and the weight of the lifted fixture. While complying with the rated lift capacity of the LLT- 1.

There are two mounting holes to secure the lifters overhead. Minimum requirements are 3/8" or 10mm screws. (Screws and washers are not included in the package)

**\*Caution:** Users are responsible to ensure all building structure, mounting solutions and components are rated and structurally sound.

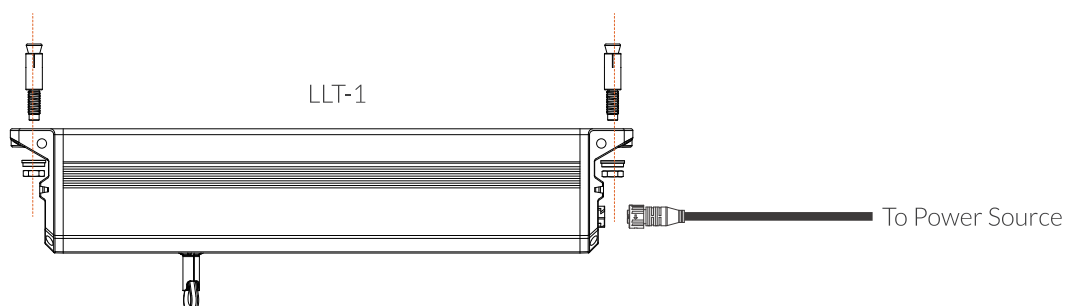

## • OPERATION INSTRUCTIONS

1. There are manual ascent and descent buttons on the control panel near the steel cable side of the lifter. These manual controls can be used when synchronizing multiple lifters to work together.

- a. Press and hold the ascent button to lift the fixture.
- b. Press and hold the descent button to lower the fixture.

2. The manual ascent/descent button functions the same as the wired Remote Control the LRC-1.

\*Custom lifting range limit can be set up when paired with the LRC-1.

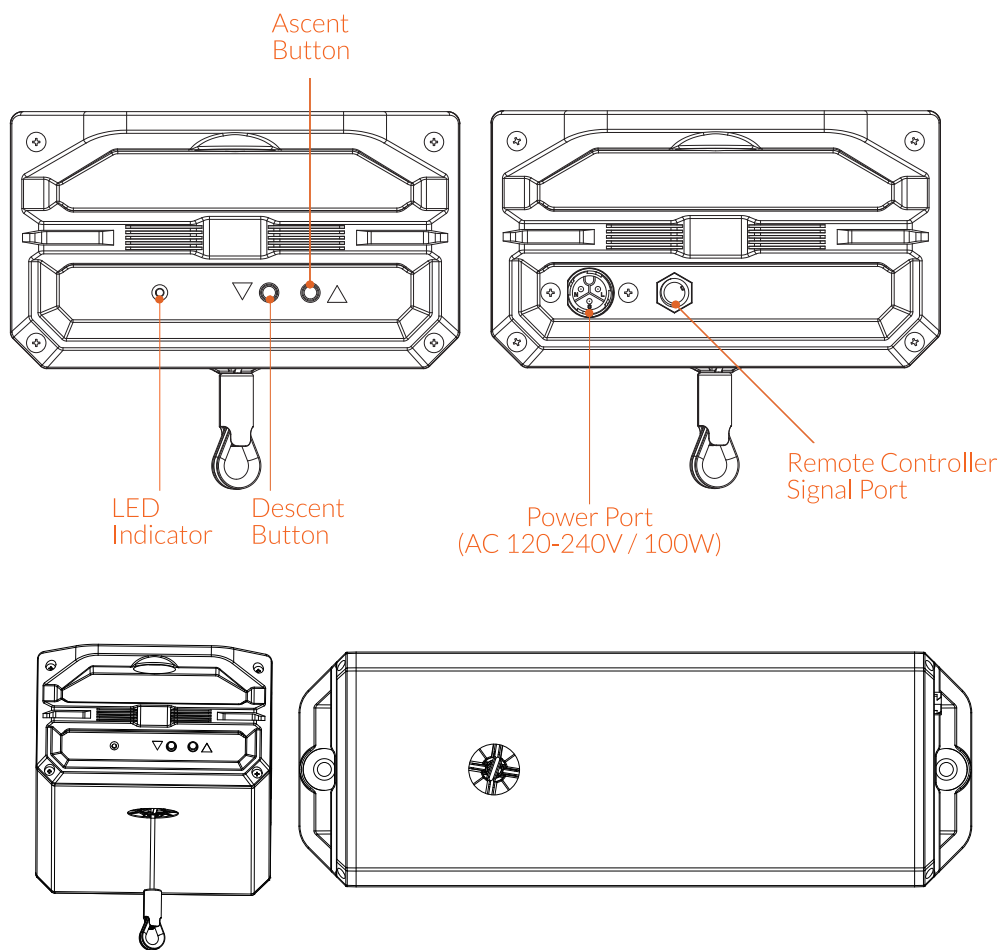

## • LED LIGHT INDICATOR

LED Indicator:

- Solid Green -Normal operation status,there is connection with the remote.
- Flashing Green-Normal operation status, there's no pairing / connection with the remote.
- Flashing Red - Error message, please refer to the troubleshooting table.

## • TROUBLESHOOTING

LED Light Indicator	(Error) status	Description & solution
<p>Connected with controller: Blinking Red LED for 10 seconds, then turns Solid Green</p> <p>Not connected with controller: Blinking Red LED for 10 seconds, then turns Blinking Green</p>	<p>Lifter has reached a level limit.</p> <p>(The lifter reached its highest or lowest setpoint)</p>	<p>Press the Down (or Up) button on the LRC-1 module to lower (or raise) the unit(s) from the ned limit position.</p> <p>If it's not working, repair or RMA may be needed.</p>
<p>Blinking Red LED for 10 seconds, then turns Solid Green</p>	<p>Reached minimum level (The lifter reached its lowest setpoint or the lowest level the hardware can reach)</p>	<p>Press the up button on the LRC-1 module to raise the unit(s) above the low limit position.</p> <p>If it's not working, repair or RMA may be needed.</p>
<p>Blinking Red LED</p>	<p>Steel cable is loose or has slacked.</p> <p>*There needs to be some weight on the cable when lifting.</p>	<p>Lower the lifter slightly, then lift a heavy object then lower it again to eliminate slack.</p> <p>If it's not working, repair or RMA may be needed.</p>
<p>Solid Red LED</p>	<p>System protection (Overloaded / too much weight on the lifter )</p>	<p>It should go back to normal operation in 60 seconds. Then test the lifter without adding any weight to it. If this fixes the problem, it's likely the ifters have been temporarily overloaded. Please make sure to keep the weight within the specified range.</p> <p>If it's still not working, repair or RMA may be needed.</p>
<p>Solid Red LED</p>	<p>Hardware malfunction</p>	<p>Repair or RMA may be needed.</p>

## • DATA SIGNAL WIRING

The LLT-1 Smart Light Lifter can operate via its control panel as shown above. To expand the LLT-1 features, such as custom lifting range and synchronized multi-lifter control; the LRC-1 Smart Lifter Remote (sold separately) is required. Follow the diagram below for a recommended "multi-lifter" and "lifter-group" setup.

The LLT-1 communication cables are daisy-chained from one lifter to another. Up to 30 LLT-1 can be interconnected and paired with the LRC-1 remote. Using multiple LLT-1 connected together will provide an easily expandable synchronized light lifter control system.

Multiple LRC-1 remotes can connect to the HCS-2 Hydro Pro to utilize the advanced features. Each LRC-1 is treated as a "lifter-group" , up to 50 LRC-1 can be connected to the HCS-2.

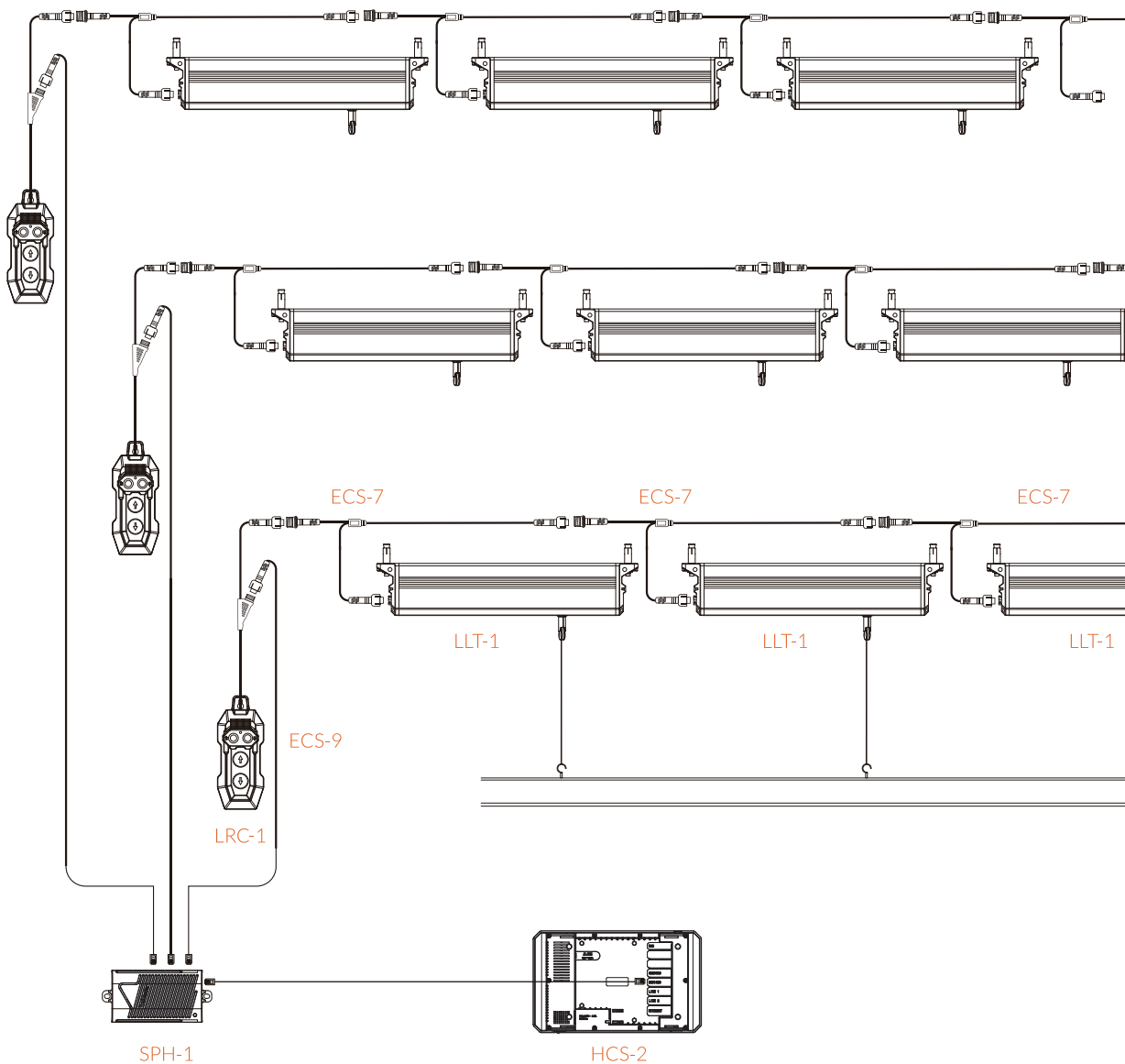

**\*Note:** A single LRC-1 remote can pair and control a signal chain of up to 30 LLT-1 lifters.

**\*Note:** The HCS-2 maincontroller can pair and control up to 50 LRC-1 remote controls.

## • LIFTER SYSTEM INITIAL SETUP

An initial setup is needed when two or more lifters are used on the same light fixtures. Follow the recommended setup instructions below to ensure the lifter system is setup correctly.

Ensure you have properly calculated the weight of all components (unistrut, lights, power cables etc.) the lifters will carry, and are within the rated weight limit.

1. Install the light lifters to a secure location overhead. Connect the power cables to the LLT-1.

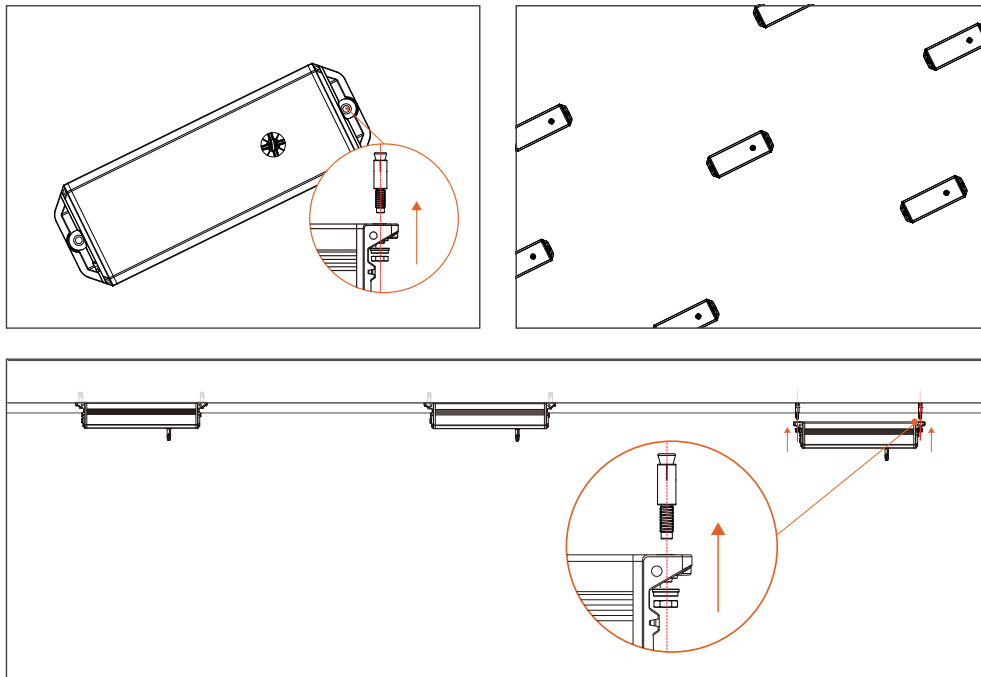

**\*Caution:** Users are responsible to ensure all components that are connected to the Smart Light Lifter are rated properly and structurally sound.

2. Use the LLT-1's descent button to individually lower the lifter's steel cable down to the same level. While manually lowering the cable on each lifter, apply a small amount of force, or attach a small weight to make sure the cable extends smoothly from the LLT-1.

**\*Use a ruler or tape measure to ensure they are all equal distance from the LLT-1 body.**

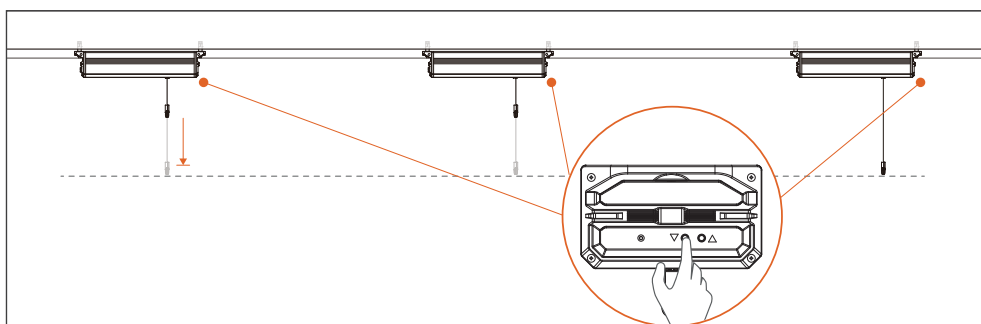

3. Connect the support system (e.g. unistrut) to the lifters' steel cable loop, so that the lifter bears a light weight.

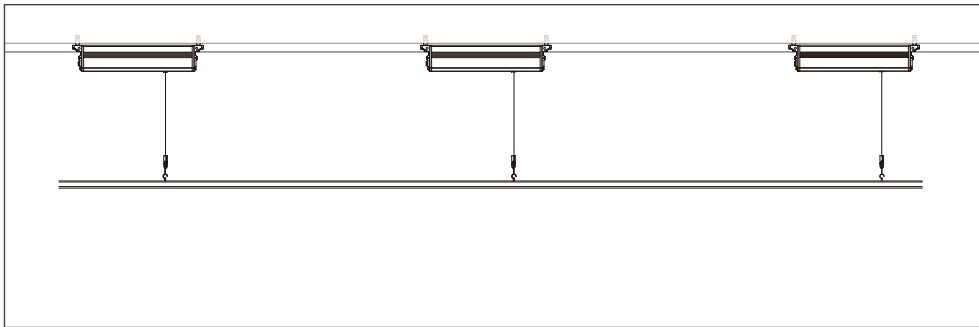

4. Ensure the support system (e.g. unistrut) is leveled and all lifters weight distribution is equal. If individual lifters need to be adjusted, use the ascent/descent buttons on the lifter.

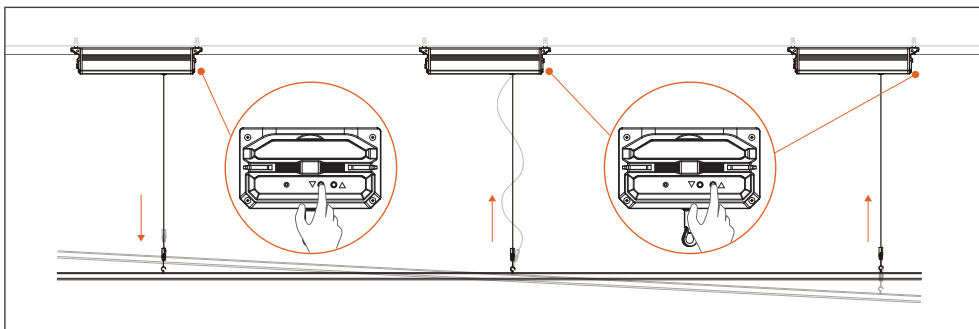

**\*Caution:** Users must address potential situations shown below before continuing the setup procedures. If one or more of the lifters are not all level, the lights may be lifted unevenly and/ or some lifters will not be bearing any weight. Manually use the up down buttons on each LLT-1 so that equal weight will be supported by each lifter.

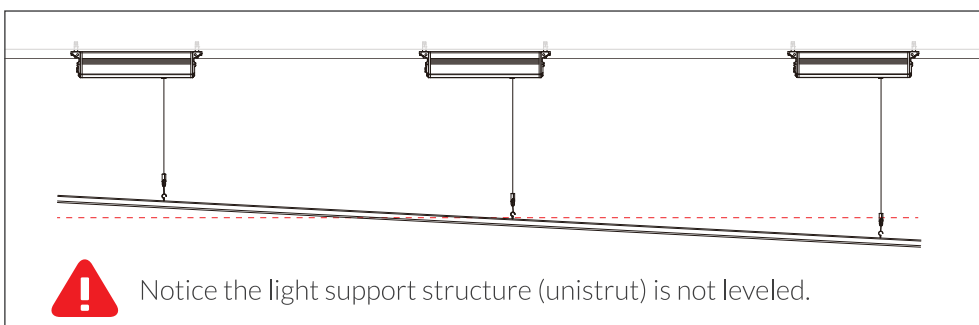
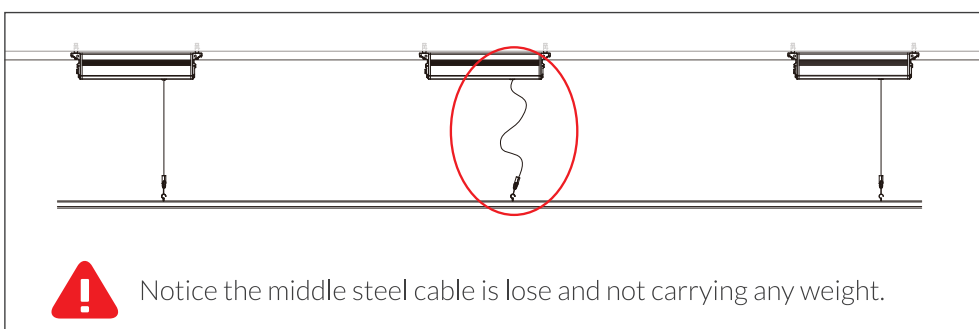

5. Daisy chain the lifters that need to be synchronized together by using the ECS-7 data cables.

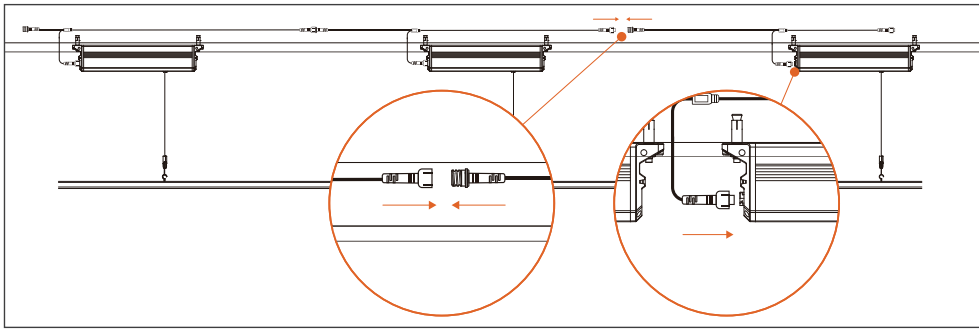

6. Connect the LRC-1 Smart Lifter Remote to the first lifter and ECS-7.

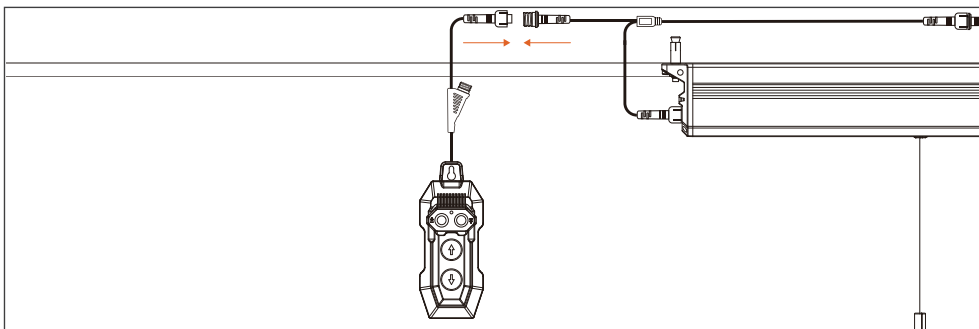

7. Address the lifter and pair the remote by pressing the LLT-1's ascent button once. When the lifter is paired with the remote, the lifter's LED will turn from blinking green to Solid Green. While the LRC-1's LED will turn from rapid blinking green (0.6s per blink) to slow blinking green (1.2s per blink). (Repeat this step until you pair all lifters in the chain. For more details on LRC-1, see P.15)

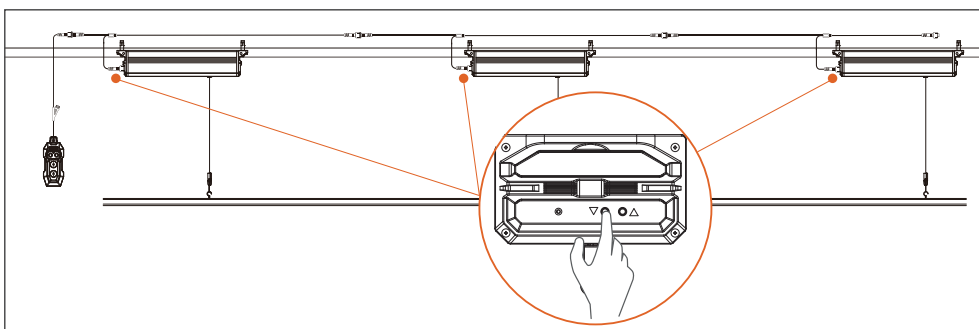

8. Test the synchronized ascent and descent via the LRC-1 Smart Lifter Remote to verify all lifters are paired and working with the remote.

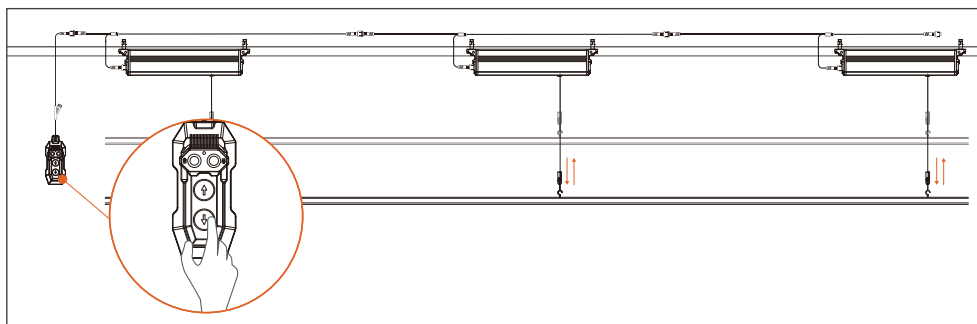

**\*Caution:** Monitor all lifters' operation. If any of the lifter(s) stops working, let go of the ascent/descent button immediately and check and troubleshoot the lifter(s) error status.

9. Install grow light into the support system (e.g. unistrut).

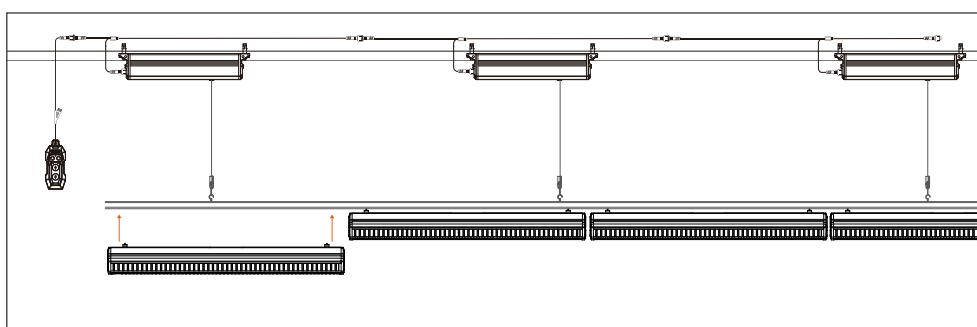

10. Set the lifters' upper and lower range limit via LRC-1 by ascending/descending to the desired height levels, press and hold the Highest/Lowest Range Setup Button until the LED indicator turns from blinking red to solid. (see P.16 for more details)

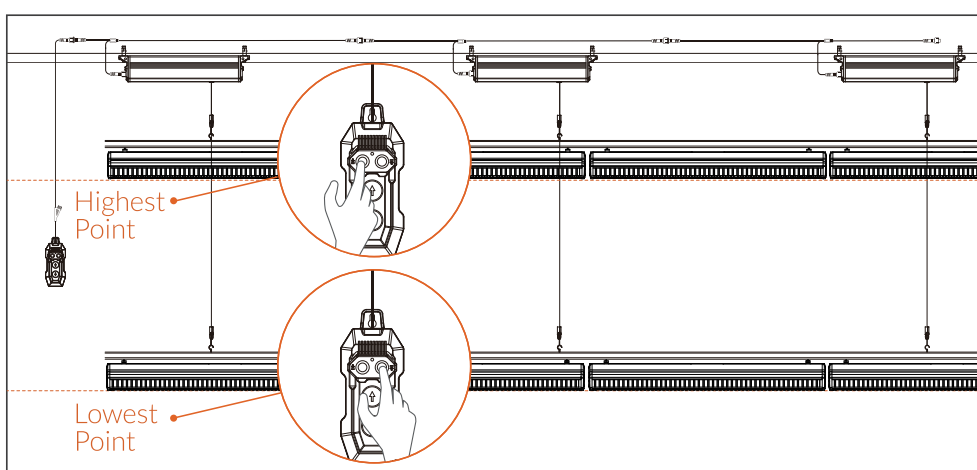

11. Connect the LRC-1 to the Hydro-X Pro (HCS-2) Maincontroller's device line via ECS-9 Data cable.

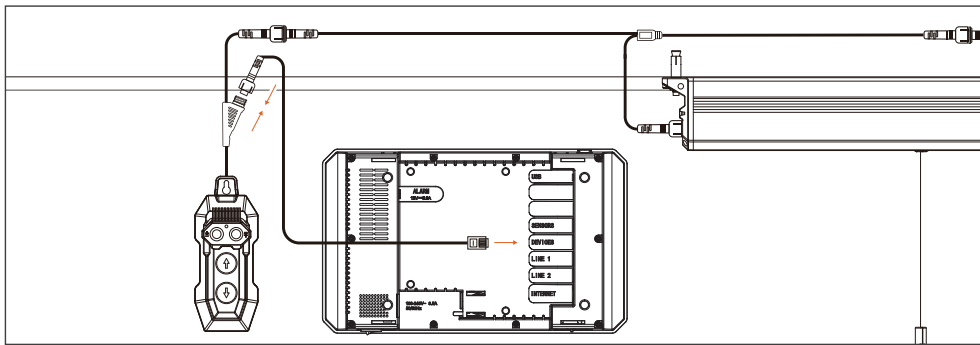

12. Address and pair the remote with HCS-2 by pressing LRC-1's Highest Range Setup Button once. when the remote is paired with the HCS-2, the remote LED will turn from slow blinking green(1.2s per blink) to solid green. A "Device Added" pop-up message will appear in HCS-2.(For more details on LRC-1, see P.15)

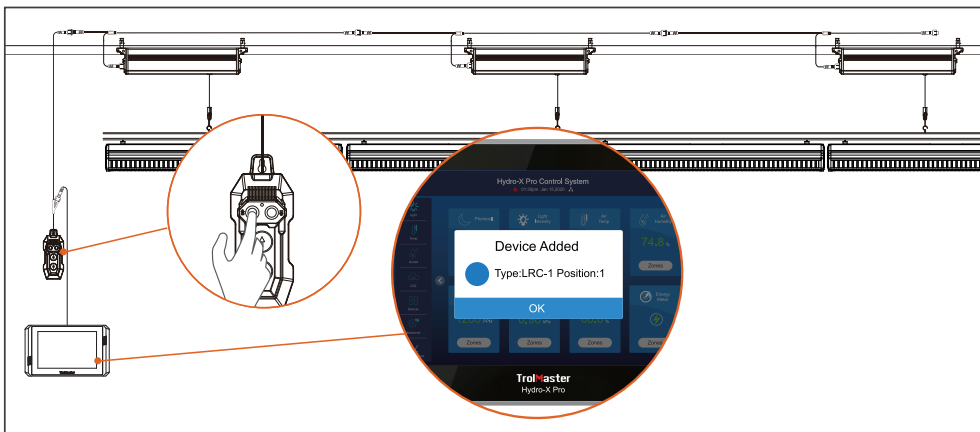

13. With multiple LRC-1 remotes, you can create multiple "lifter-group". Connect the LRC-1 remotes to the HCS-2 via SPH-1 splitter hub for advance features such as "synchronized lifter-group control" . (For more details, see Hydro-X Pro user manual and tutorial video.)

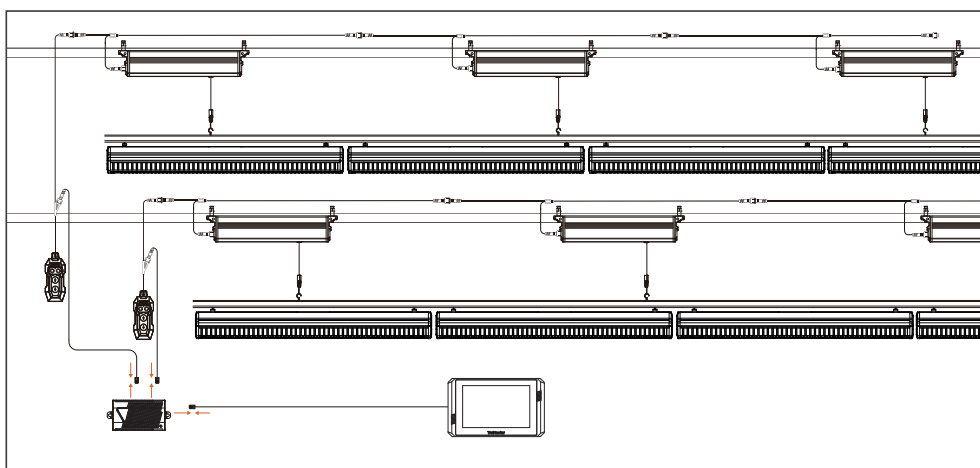

# Smart Lifter Remote (LRC-1)

## • OVERVIEW

The LRC-1 Lifter Remote Control is designed to be used with the LLT-1 light lifter. Its plug & play easy installation enables users to easily install and operate the light lifter(s) from a distance, and program LLT-1 light lifters maximum and minimum range.

The LRC-1 LED indicator will also show its operation, program settings and height limit for users easy reference.

The LRC-1 Lifter Remote can be connected with the Hydro-X Pro for advanced features such as lifter-group control.

## • SPECIFICATION

Input Voltage and Amperage:	12V~, 0.1A
Working Environments:	Temperature 32~104°F (0~40°C) Humidity ≤90%RH
Package Dimensions:	5.12" x 7.36" x 3.46" 130mm x 187mm x 88mm
Weight:	1.32lbs / 0.6kg

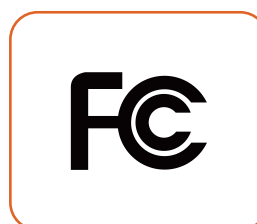
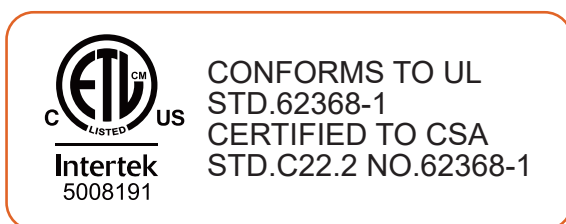

## • PACKAGE CONTENTS

1 x Smart Lifter Remote (LRC- 1)

1 x 12ft RJ12 to 4-Pin IP65 Connector Cable (ECS-9)

## • INSTALLATION

Connect the longer jack on the LRC-1 directly to the Remote Controller Signal Port on the LLT-1 light lifter if you are only using one lifter. If you want to synchronize multi-lifter control with one LRC-1 remote, connect the longer jack to a connection cable and daisy chain these lifters together (follow the “Data Signal Wiring” guide on P8).

Address and pair the connected remote and lifter by pressing the lifter's ascent button. If you are connecting the remote to a daisy-chained multi-lifter, address and pair all lifters individually by pressing the ascent button on the lifters.

Connect the shorter cable to ECS-9, and use the ECS-9 RJ12 port to connect the controller to Hydro-X Pro main controller.

Address the remote and the HCS-2 by pressing LRC-1's Highest Range Setup Button once. When the remote is paired with the HCS-2, the remote LED will turn from slow blinking green (1.2s per blink) to solid green. A “Device Added” pop-up message will appear in HCS-2.

**\*Note:** A single remote can pair and control a signal chain of up to 30 lifters.

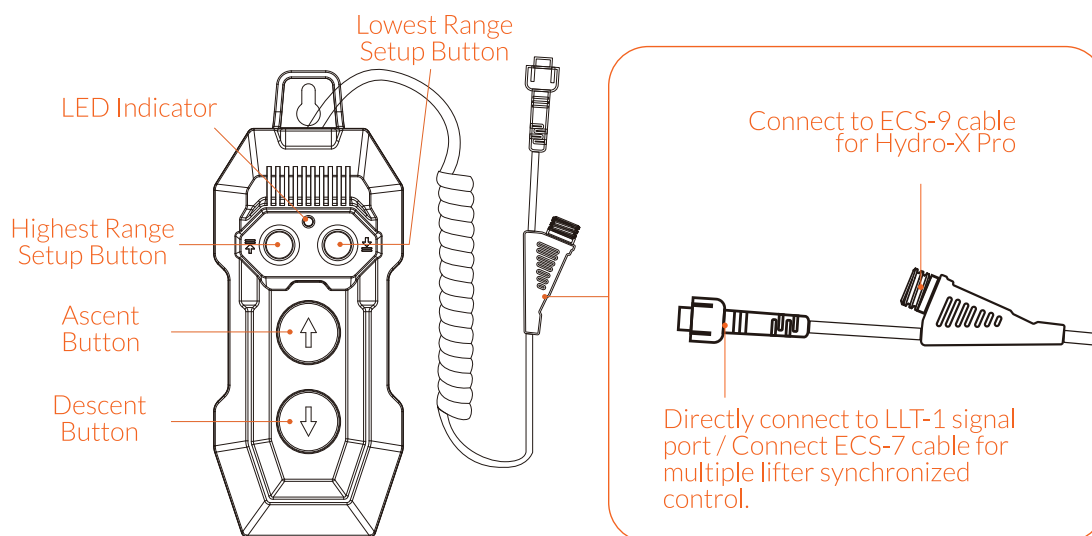

## • OPERATION INSTRUCTIONS

1. The LED indicator will be blinking green when the ascent or descent button is held.
2. Once the highest or lowest setpoint is positioned, hold the highest or lowest range setup button on the LRC-1 for 3 seconds to lock the position in memory, The LED will blink red while saving the setting. When it turns to solid red, that means the position has been assigned and locked successfully.

3. The highest range must be set higher than the lowest, and vice versa. The LED indicator will blink green for 5 seconds once it's been sent, the remote shall only be able to move the lights up or down within the setup range.

4. The LED indicator will blink red for 5 seconds when the cable reaches the upper or lower range limit, and cannot go further.

\* Press the up or down button to move the lifter from the positioning limit.

Reset Range Limit: Hold both the highest and lowest range setup buttons for 3 seconds.

Unpair Lifter(s) in signal chain: Hold both the highest range setup button and ascent button for 3 seconds. The LED indicator will be blinking red and green, the LED will be solid red after 3 seconds indicating the unit has been successfully unpaired.

Reset Range Limit: Hold both the highest and lowest range setup buttons for 3 seconds. The LED indicator will be blinking red and green, solid red after 3 seconds indicates successful range limit removal.

## • LED LIGHT INDICATOR

LED Light indicator	Status
Solid Green LED	Normal operation status. The remote is connected and paired with both the lifter(s) and main controller.
Rapid Blinking Green LED (0.6s per blink)	Normal operation status. The remote is not paired/ connected to both the lifter(s) and main controller. or Normal operation status. The remote is connected and paired to the main controller, but not paired/connected to the lifter(s).
Slow Blinking Green LED (1.2s per blink)	Normal operation status. The remote is connected and paired to the lifter(s), but not paired/connected to the main controller.
Blinking Red LED	One or more of the paired lifter(s) in the signal chain has an error/offline. Check the LED indicator on the lifter(s) to troubleshoot (details on P.7).

**\*Note:** The blinking red indicator will turn green after 10 seconds. The indicator will blink red for another 10 seconds if the error persists when the user operates the LRC-1 Remote Control.

**\*Caution:** Always monitor all lifters' operation when lifting or lowering via the remote. (Especially when operating under synchronized multi-lifter usage) If any of the lifter(s) stopped working, let go of the ascent/descent button immediately. Check and troubleshoot the lifter(s) error status.



**WARNING :** DO NOT allow the Light Lifter System to be exposed to water or excessive heat. DO NOT open or attempt to repair or disassemble the Lifter, as there are no user-serviceable parts inside. Opening the Lifter will void the warranty.

If the surface of the Light Lifter System is dirty, wipe it with a dry towel. The Light Lifter System operates under natural ventilation conditions.



**AVERTISSEMENT :** NE PAS exposer la carte de contact sec Light Lifter System à l'eau ou à une chaleur excessive. NE PAS ouvrir ou tenter de réparer ou de démonter le Lifter, car il ne contient aucune pièce réparable par l'utilisateur. L'ouverture du Lifter annulera la garantie.

Si la surface de la carte de contact sec Light Lifter System est sale, essuyez-la avec une serviette sèche. La carte de contact sec Light Lifter System fonctionne dans des conditions de ventilation naturelle.

For any issues or concerns with our products, DO NOT return them to the store. Please contact our tech support department at [support@thinkgrow.com](mailto:support@thinkgrow.com) or call 877-420-9876.

December 2025 ©2025 ThinkGrow™ All rights reserved.